

CALL FOR ARTISTS

RECHARGE PARK SWING ART PROJECT

Issued By: King of Prussia District

Project Type: Public Art

Number of Artworks: 4 Painted Swings

Artist Compensation: **\$1,250** per swing, inclusive of materials

PROJECT OVERVIEW

King of Prussia District is seeking artists to submit concept proposals to transform unique swings at Recharge Park as colorful, engaging installations that celebrate community, reflect the surrounding environment and spark creativity. Selected designs will become a lasting part of this lively public space—crafted to be durable, safe, accessible and inspiring for everyone who visits.

Artists may apply to paint **one swing or all four swings**. Final artist selection may include multiple artists or a single artist creating a cohesive set.

ARTWORK LOCATION & DESCRIPTION

The swings are large-scale outdoor structures constructed primarily of **weather-resistant composite board (GFRP)** with aluminum and stainless-steel components. Artwork will be painted directly onto designated composite surfaces of the swing structure.

The manufacturer Noblewins is a public art company that repurposes retired wind turbine blades into durable, functional benches for communities, parks and schools across the United States. Drawing on deep experience in the renewable energy sector, the team transforms this high-performance, industrial-grade material into customizable public art pieces that help address turbine blade waste while enhancing shared spaces.

Approximate Dimensions of Each Swing:

- Overall footprint: 36" (D) x 96" (W) x 86" (H)
- Multiple visible faces: front, back, and sides

All artwork must be appropriate for **outdoor, high-touch, public use** and withstand sun, rain, humidity and daily interaction. **See specification drawings under Addendum A.**

Learn more about the product: <https://noblewins.com/pages/public-art>

Site Location:

680 Freedom
Business Center
Drive, King of Prussia
PA 19406



Project Design:

Swings are located along sidewalk highlighted within square box



THEME

Artists are encouraged to interpret one or more of the following concepts:

- Nature and local ecology
- Local history
- Movement, rest, and reflection
- Community connection and resilience

Abstract, representational or graphic styles are welcome.

BUDGET

- \$1,250 **per swing** (all-inclusive)
- Artist compensation must cover design, labor, materials, paints, sealants and finishing
- No additional funds will be available beyond the stated amount

ELIGIBILITY

- Open to local and regional artists
- Must be 18 years or older
- Individual artists or teams may apply
- Public art experience preferred but not required

SUBMISSION REQUIREMENTS

Artists must submit the following:

1. **Artist Statement** (250–500 words)
2. **Concept Proposal** describing the design approach for one swing (or all four)
3. **Design Mockup or Sketch** applied to the swing form (hand-drawn or digital)
4. **Portfolio or Resume** with 3–5 relevant examples of past work



5. **Materials & Durability Plan** outlining paint types, sealants and weather protection

FABRICATION REQUIREMENTS

- All paints must be **UV-stable, exterior-grade and non-toxic.**
- A protective clear coat is required.
- Artwork cannot be installed on the swing itself or the chain and support system. Only the composite surfaces of the structure.
- Seating surfaces must remain safe and slip resistant.
- Final designs are subject to approval prior to painting.
- Painting must occur on-site, to be coordinated with King of Prussia District.

SELECTION CRITERIA

Submissions will be evaluated based on:

- Artistic quality and originality (30%)
- Relevance to theme and site (25%)
- Durability and feasibility (20%)
- Safety and accessibility considerations (15%)
- Artist experience (10%)

JURY PROCESS

King of Prussia District will convene a jury to review all eligible submissions and select the final artist(s). The jury may include representatives from community stakeholders, design professionals and members of the King of Prussia District network. Final selections will be made based on the stated evaluation criteria and overall alignment with the goals of the project.



TIMELINE

- Call for Artists Released: March 20, 2026
- Questions Due: April 13, 2026
- Submissions Due: May 8, 2026
- Artist(s) Selected: May 13, 2026
- Design Finalization: May 15, 2026
- Painting Period: May 16 – June 2, 2026
- Installation & Public Unveiling: June 4, 2026

RIGHTS & MAINTENANCE

- Artists retain copyright of their artwork.
- King of Prussia District retains the right to photograph and promote the artwork.
- King of Prussia District will be responsible for long-term maintenance.
- Artwork may be repaired, altered or removed if damaged or deemed unsafe.

SUBMISSION INSTRUCTIONS

Email: Kaitlyn@kopbid.com

Subject Line: Recharge Park Swing Art Proposal – [Artist Name]

Questions may be directed to the same email address. We look forward to receiving creative proposals that bring color, meaning and community identity to these unique public swings.



ADDENDUM A:

See attached documents courtesy of Noblewins.



Transforming Your Noblewins Piece into a Custom Work of Art

Every Noblewins product is designed to serve as a high-quality, durable foundation for your community's creativity. This packet provides essential information to help you collaborate with local artists or groups. Whether you choose to apply a hand-painted mural or a professional vinyl wrap, these standards ensure your custom design remains vibrant and protected for years to come.

Surface Prep (Painting or Vinyl Wrapping)

To ensure the best results, please follow these guidelines:

- The PRIMED surface must remain clean and dry. Paint within 30 days of delivery for optimal adhesion and mural longevity. If the product is stored indoors and protected from moisture and sunlight, the PRIMED surface will be preserved for a longer period of time.
- If your product arrives wrapped, remove any wrapping immediately upon delivery. Leaving it wrapped can trap moisture and damage the primer.
- If applying paint or vinyl wrap after 60 days, or the PRIMED surface no longer appears clean, we recommend a light sanding or cleaning to remove any dust or surface breakdown before applying paint or vinyl wrap.

Applying an Artist's Mural



Step 1: Prep the Surface

- Wipe clean with a damp cloth
- If dusty or slick, lightly scuff with 220-grit sandpaper and wipe again
- Ensure the surface is dry before painting

Step 2: Recommended Paints

- Sherwin-Williams Resilience, SuperPaint, or Duration Exterior Acrylic
- Nova Color Acrylic Artist Paints
- Behr Ultra or Marquee Exterior Acrylic Latex

Step 3: Optional Clear Coat for Protection

- Sher-Clear 1K (Sherwin-Williams)
- World's Best Graffiti Coating
- Golden MSA Varnish (Gloss or Satin) wit UVLS
 - Apply 1-2 coats once mural is fully dry (24-48 hrs)
 - Always test a small area first for compatibility

Applying Vinyl Wrapping



Recommended Vinyl Materials

- Avery Dennison MPI 1105 SuperCast (10 year)
- 3M Controltac Graphic Film IJ180 (5 year)
- Orajet 3951RA + Oraguard 290 laminate (5 year)

Application Tips

- Clean surface thoroughly
- Apply between 60°F - 80°F
- Use heat guns and rubber tools to remove air pockets
- Laminate for UV/graffiti protection



EVERGLADE



Width: 96"

Depth: 36"

Height: 86"

Paintable Surface Area: 124ft²





NOBLEWINS

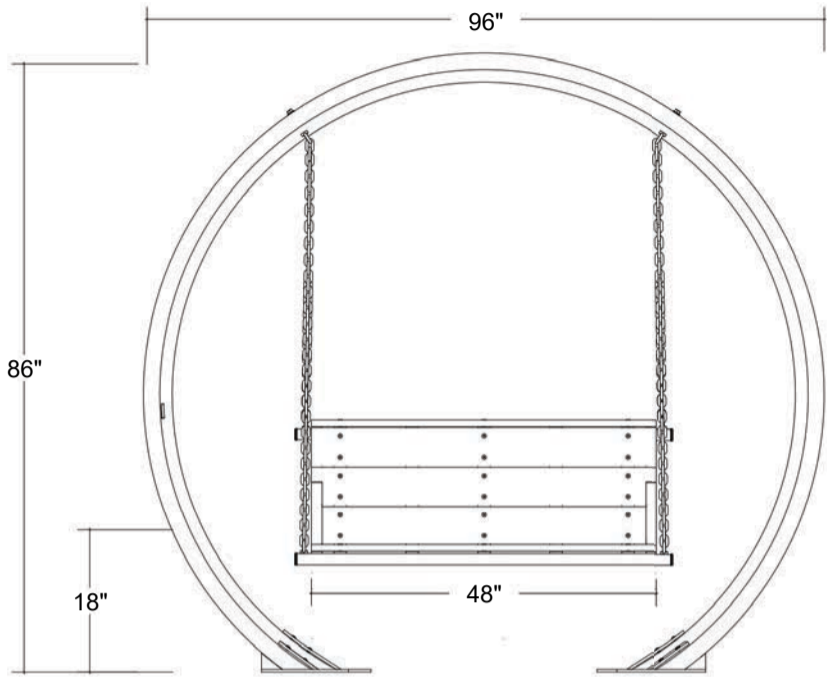

Front View

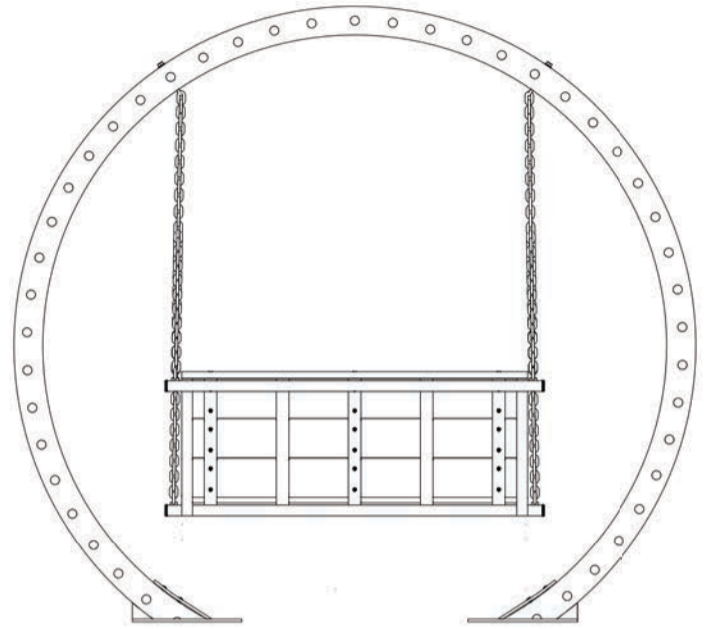

Back View

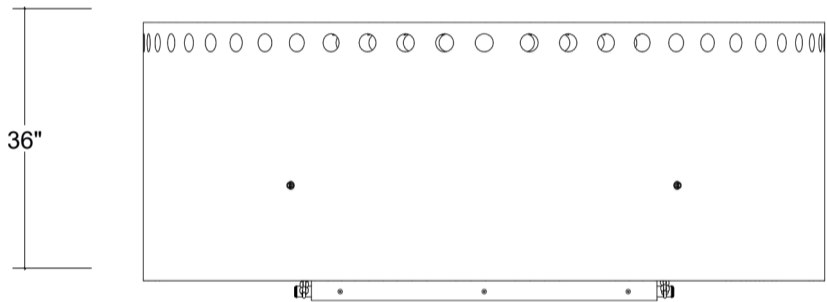

Top View

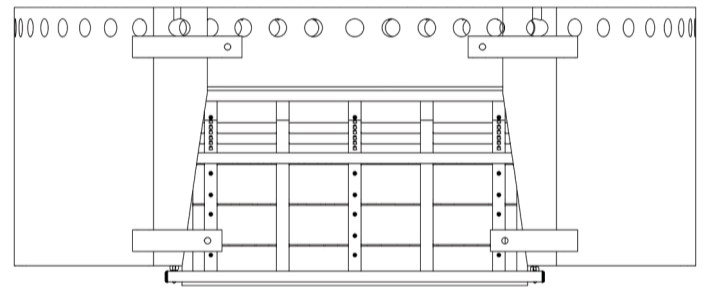

Bottom View

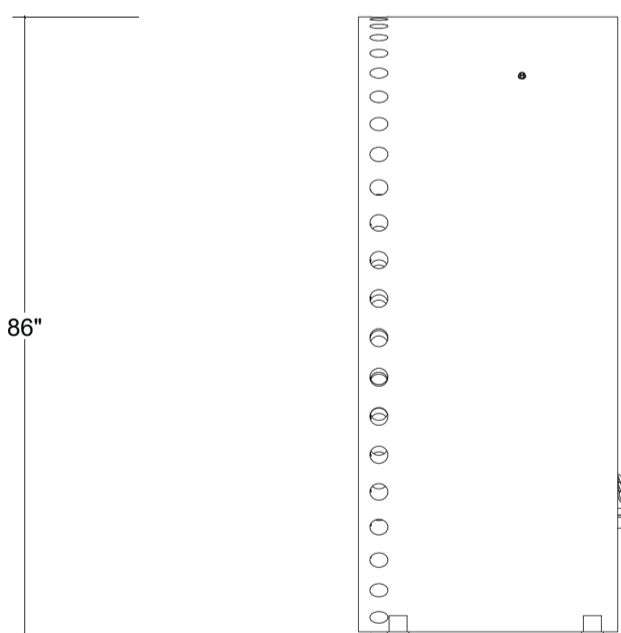

Left View



Right View

Everglade Noblewins	Specification		Product Composition		
	Metric	Details	Material	% /Weight	Details
Product Footprint	36"(D) x 96"(W) x 86"(H)		GFRP	≈ 88.2%	Reclaimed from retired wind turbine blades, engineered for extreme weather resistance and hurricane-force durability.
Suggested Concrete Pad Size (ADA)	156" x 216" x 4"		Composite Board	≈ 7.2%	Weather-resistant material repurposed from post-industrial composite waste streams.
Product Weight	≈ 1,500 lbs		Aluminum	≈ 3.9%	Corrosion-resistant structural components for long-term integrity in public spaces.
Anchoring Style	Surface Mounted: 1/2" Wedge Anchors		316 Stainless Steel	≈ 0.7%	Premium-grade hardware for maximum oxidation resistance and permanent security.